

**TME2200**  
CUTTER, HANDLE

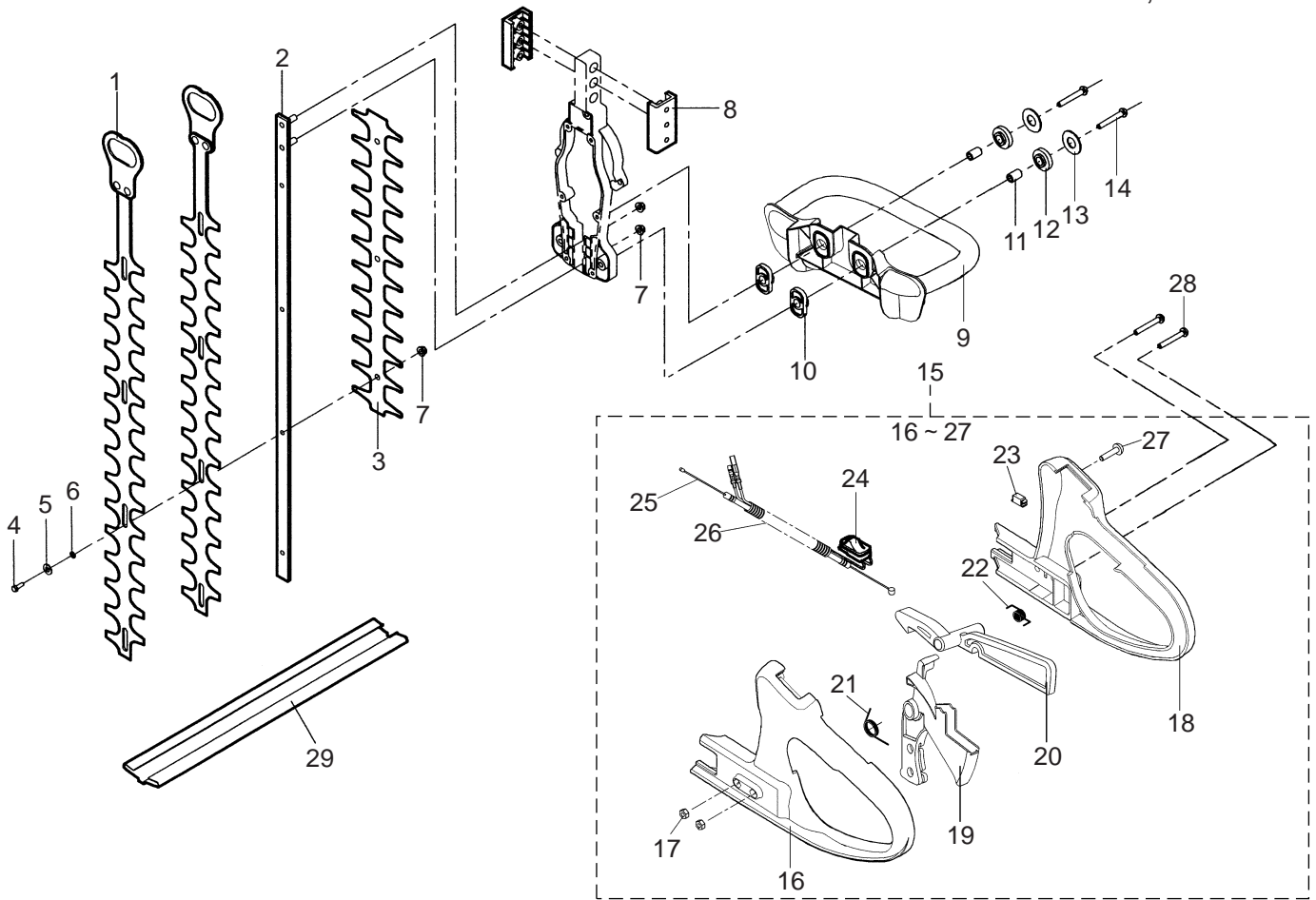

**PARTS LIST**

46014-666-01

Oct,2008

REF. No.	PARTS No.	PARTS NAME	CUTTER, HANDLE			2/2	REMARKS
			Q'TY	INCLUDING			
1	91054   122	CUTTER B	2				
2	11051   132	CUTTER GUIDE	1				
3	51090   135	PROTECTOR	1				
4	31029   110	STEP BOLT(S)	4				22L
5	670V   0700	CONICAL SPRING WASHER	4				M6
6	68002   101	CUTTER WASHER	4				M6
7	584L   0600	U-HEXAGON NUT FLANGE	6				M6
8	36006   128	ABSORBER	2				
9	51027   279	HANDLE	1				
10	36005   176	VIBRO-ISOLATING RUBBER	2				
11	11083   381	COLLAR	2				
12	36005   169	VIBRO-ISOLATING RUBBER	2				
13	68036   268	WASHER	2				5.5 x 25 x t1.2
14	413U   0530	SOCKET SCREW FLANGE	2				M5 x 30(SW)
15	71014   457	HANDLE ASS'Y	1				
16	51106   143	HANDLE R		1			
17	562L   0500	U-HEXAGON NUT			2		M5
18	51106   144	HANDLE R		1			
19	11095   182	LEVER		1			
20	11095   181	LEVER		1			
21	68013   321	SPRING		1			
22	68013   367	SPRING		1			
23	91033   135	BLIND COVER		1			
24	71148   176	STOP SWITCH ASS'Y		1			
25	91001   323	THROTTLE WIRE		1			
26	41003   187	TUBE		1			
27	474L   0420	(+)TAPPING SCREW		4			M4 x 20
28	412L   0540	SOCKET SCREW		2			M5 x 40
29	36065   475	COVER		1			
30							