

TM3100

CUTTER , HANDLE

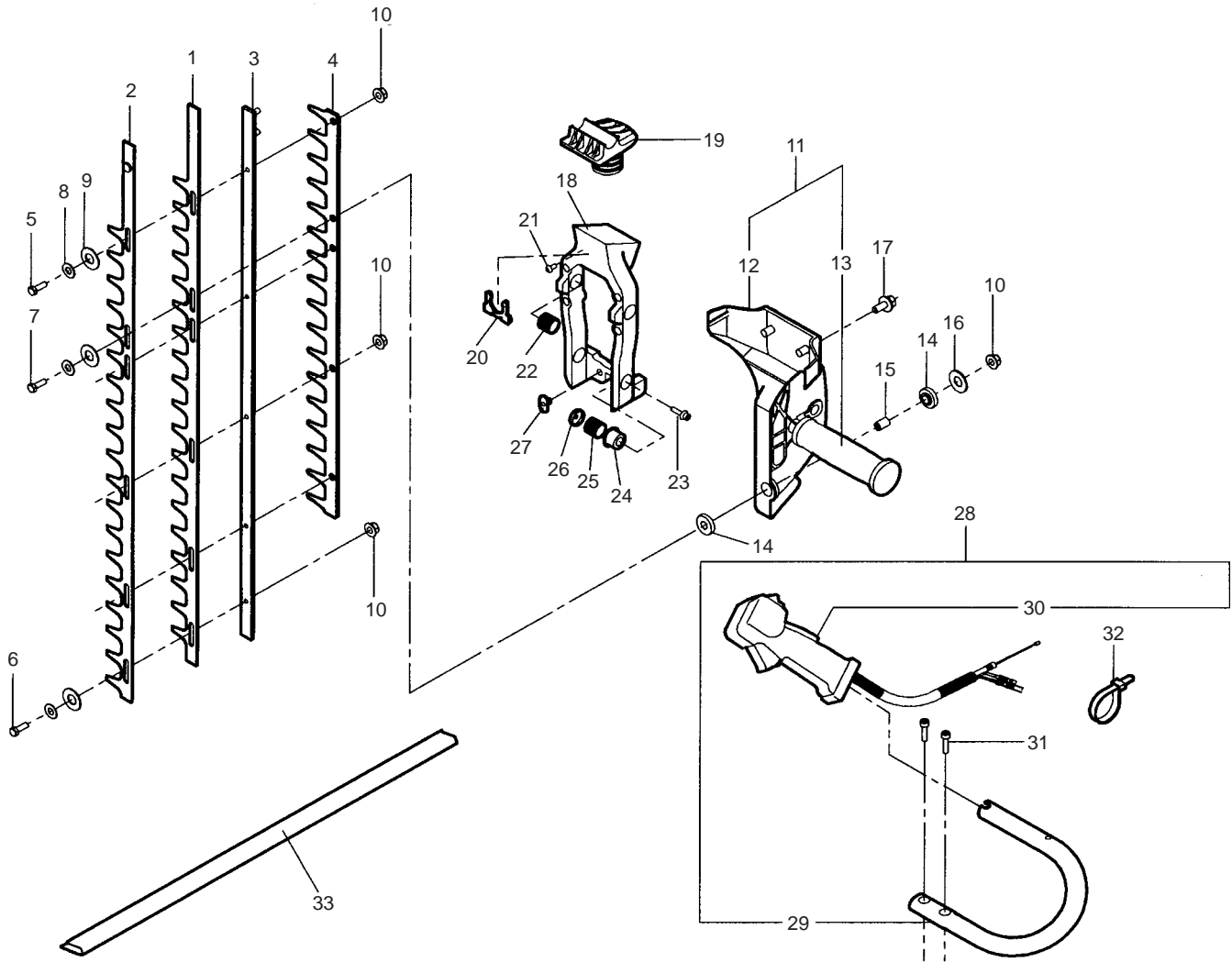

PARTS LIST

REF. No.	PARTS No.	PARTS NAME	Q'TY		REMARKS
				NCLUDNG	
1	91053 122	CUTTER(A)	1		
2	91054 113	CUTTER(B)	1		
3	11051 128	CUTTER GUIDE	1		
4	51090 129	PROTECTOR	1		
5	31029 112	STEP BOLT(S)	1		
6	31029 105	STEP BOLT(S)	4		
7	31030 105	STEP BOLT(L)	1		
8	670V 0700	CONICAL SPRING WASHER	6		M6
9	68002 101	CUTTER WASHER	6		
10	584L 0600	U-HEXAGON NUT FLANGE	6		M6
11	71014 378	HANDLE ASS'Y	1		
12	51027 240	HANDLE	1		
13	36007 136	HANDLE GRIP	1		
14	36005 169	VIBRO-ISOLATING RUBBER	2		
15	11083 376	COLLAR	1		
16	68036 163	WASHER	1		
17	31057 235	BOLT	2		M5 x 20
18	51022 171	BRACKET	1		
19	51022 180	BRACKET	1		
20	11086 179	STOPPER	1		
21	477L 0408	(+)TRUSS TAPPING SCREW	2		M4 x 8
22	68013 326	SPRING	2		
23	423U 0515	SOCET SCREW FLANGE	4		M5 x 15
24	11102 210	HOLDER	4		
25	68013 327	SPRING	2		

