

PARTS LIST

46014-664-00

Feb, 2008

REF. No.	PARTS No.		PARTS NAME	CUTTER, HANDLE		3/4	REMARKS
				QTY	PRICE ( )	RECOMM(%) Lot.100	
				NCLUDNG			
1	91054	115	CUTTER(B)	2			
2							
3	11051	129	CUTTER GUIDE	1			
4	51090	135	PROTECTOR	1			
5	31029	105	STEP BOLT (L)	1			
6	31029	110	STEP BOLT (S)	3			
7	68002	101	CUTTER WASHER	4			
8	584L	0600	U-HEXAGON NUT FLANGE	4			M6
9	51027	276	HANDLE	1			
10	31057	235	BOLT	2			M5 x 20 (SW, PW)
11	51022	184	BRACKET	1			
12	214B	5000	O-RING	1			S50
13	11086	179	STOPPER	1			
14	477L	0408	(+) TRUSS TAPPING SCREW	2			
15	68013	326	SPRING	2			
16	423U	0515	SOCKET SCREW FLANGE	4			
17	11102	210	HOLDER	4			
18	68013	327	SPRING	2			
19	11102	209	HOLDER	4			
20	31038	102	FIXING NUT	2			
21	71014	452	HANDLE ASS'Y	1			
22	51106	141	HANDLE R	1			
23	51106	142	HANDLE R	1			
24	91010	195	THROTTLE LEVER	1			
25	36081	117	LOCK LEVER	1			

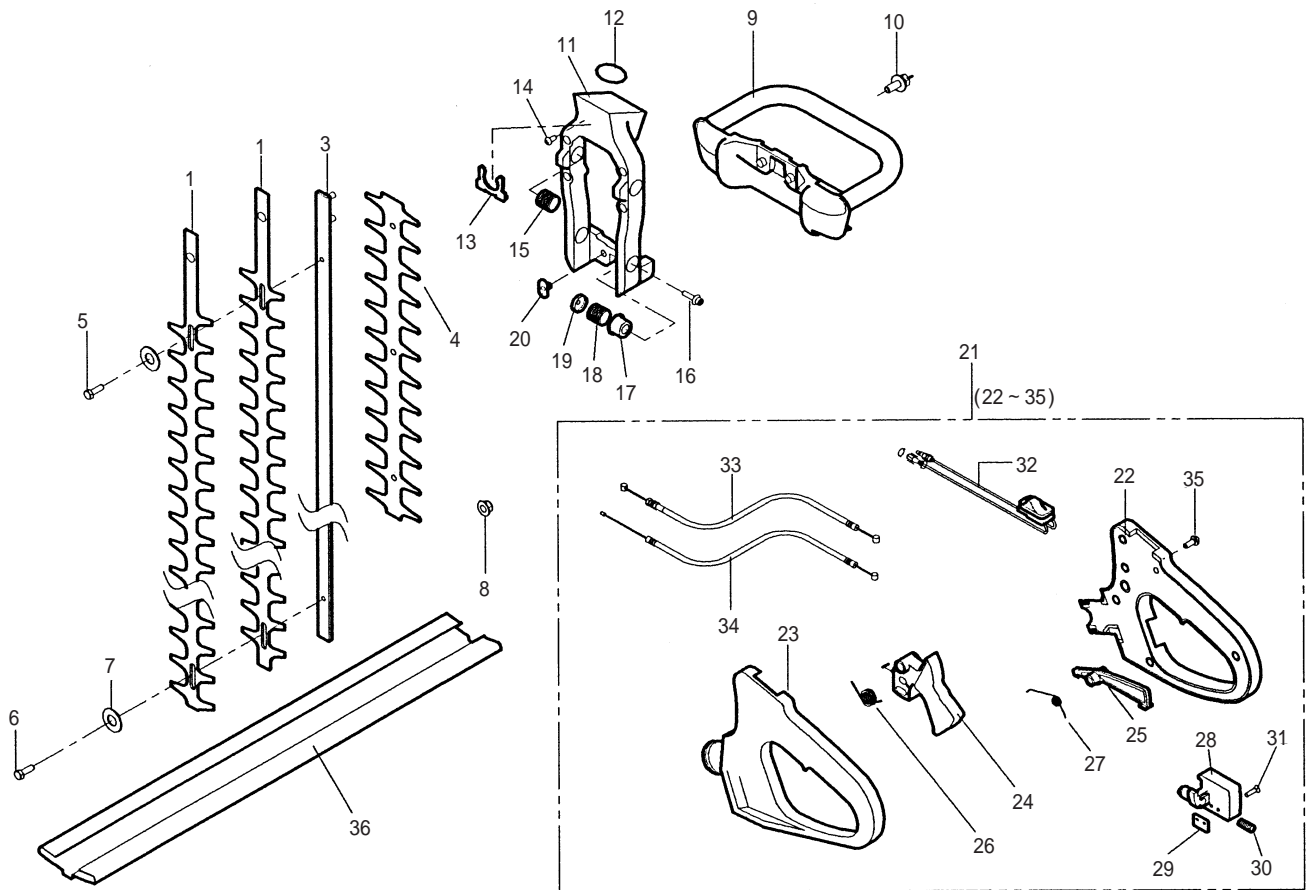

PARTS LIST

46014-664-00

REF. No.	PARTS No.	PARTS NAME	CUTTER, HANDLE		4/4	RECOMM(%) Lot.100	REMARKS
			QTY	PRICE ( )	Feb,2008		
			NCLDNG				
26	68013 321	SPRING	1				
27	68013 322	SPRING	1				
28	36061 147	KNOB	1				
29	11050 167	FIXING PLATE	1				
30	68013 323	SPRING	1				
31	465L 0310	(+) TAPPING SCREW	2				
32	71148 174	STOP SWITCH ASS'Y	1				
33	91057 108	BRAKE WIRE	1				
34	91001 310	THROTTLE WIRE	1				
35	471L 0420	(+) TAPPING SCREW	4				
36	36065 472	COVER	1				
37							
38							
39							
40							
41							
42							
43							
44							
45							
46							
47							
48							
49							
50							