

This catalog covers:
TK045D-□C52

This fig. covers:
TITLE

PARTS CATALOG

2-STROKE ENGINE

TK045D

PRODUCT CODE	NOTE
TK045D-AC52	BLOWER

This catalog covers:
TK045D-□C52

PARTS CATALOG INTRODUCTION

This parts catalog lists parts and sub-assemblies provided as service parts.

When it becomes necessary to replace parts, always use KAWASAKI GENUINE PARTS which have passed strict inspection which guarantees quality and performance.

1. HOW TO ORDER PARTS

- When ordering the parts, be sure to use the parts catalog corresponding to the product code. Check the product revision codes on the product and the catalog.
 Product Code (example) : FA130D-AA00
└──────────────────┘
 Product Revision Code
- Specify the part code (all digits) exactly as listed in this catalog on your parts order.
- The parts not shown in the illustrations of this catalog are not sold separately; only the complete units or next higher assemblies illustrated are supplied as the service parts.

2. EXPLANATION OF PARTS CATALOG FORMAT

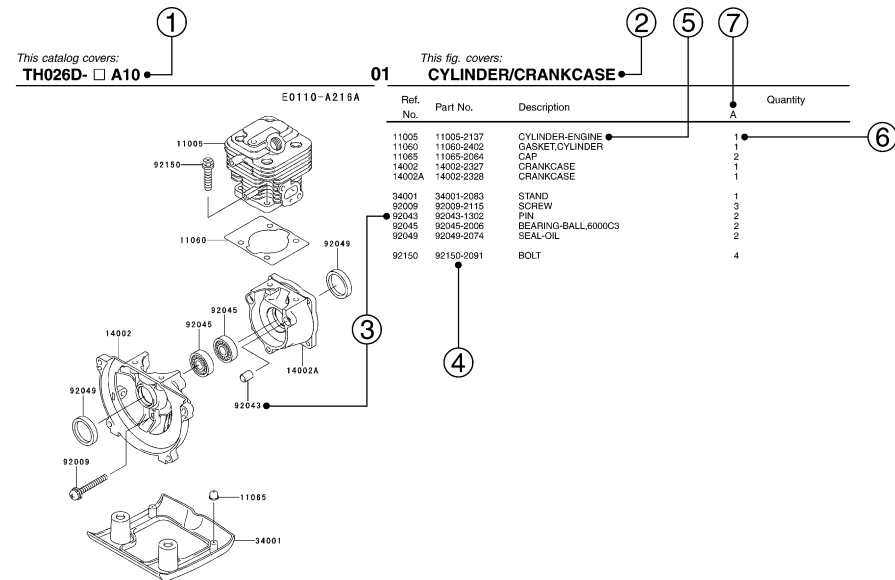

1) Product Code

This code describes the product code covered by this catalog. The product revision code, which is a part of the product code, is omitted.

2) Part Group Title

This title is the representative name for the group of parts illustrated on the page.

3) Reference Number

The reference numbers are shown on the illustration and the list as the link between them.

This fig. covers:

PARTS LIST INFORMATION

4) Part Number

This is the key of your parts ordering.

Three kinds of part number are used in this catalog.

a. Structure 1

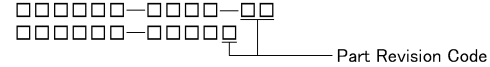

b. Structure 2

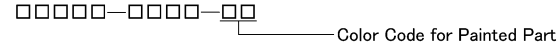

c. Standard Hardware Number

(for bolts, nuts, washer, or the like)

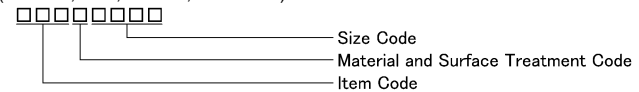

5) Description and Additional Information

The part name, the location, the size, and the serial number as additional information, etc. are described here. Use them to find out and check the part required.

When a part number is changed without change of the product revision code and the changed parts are not interchangeable, the serial number of the product is noted as follows;

- (FA130 - 100001) : Affected units are from beginning of the product of the product code up to and including this serial number.
- (FA130 - 100002 -) : Affected units are from this serial number and above.
- (FA130 - 100002 - FA130 - 110001) : Affected units are in this serial number range.

6) Quantity

The figure shows quantity of the part required at the indicated position on the illustration and for the specified product revision code.

The asterisk (*) on this column means the part can be used as the substitute on the product and is supplied until the stock is exhausted.

Note:Some small parts will be supplied by units.

Example: If six (6) bolts are ordered and the minimum quantity per unit is five (5), two (2), units of the bolt will be delivered.

7) Product Revision Code

This Code indicates an important change which affects the service parts interchangeability.

3. ABBREVIATIONS

#.....Number	FR.....Front	RH.....Right Hand
&.....And	G.....Gram	RPM.....Revolutions Per Minute
(+).....Plus	HEX.....Hexagonal	RR.....Rear
(-).....Minus	ID=.....Inside Diameter	STD.....Standard
2ND.....Second	IN.....Inch	T.....Teeth
3RD.....Third	L=.....Length	T=.....Thickness
4TH.....Fourth	LH.....Left Hand	U/S.....Under Size
A.....Ampere	LWR.....Lower	UPP.....Upper
AR.....As Required	MM.....Millimeter	V.....Volt
ASSY.....Assembly	O/S.....Over Size	W.....Watt
CNT.....Center	OD=.....Outside Diameter	
COMP.....Complete	REF.....Reference	

This catalog covers:

TK045D- □ C52

This fig. covers:

01 CYLINDER/CRANKCASE

E0110-A506A

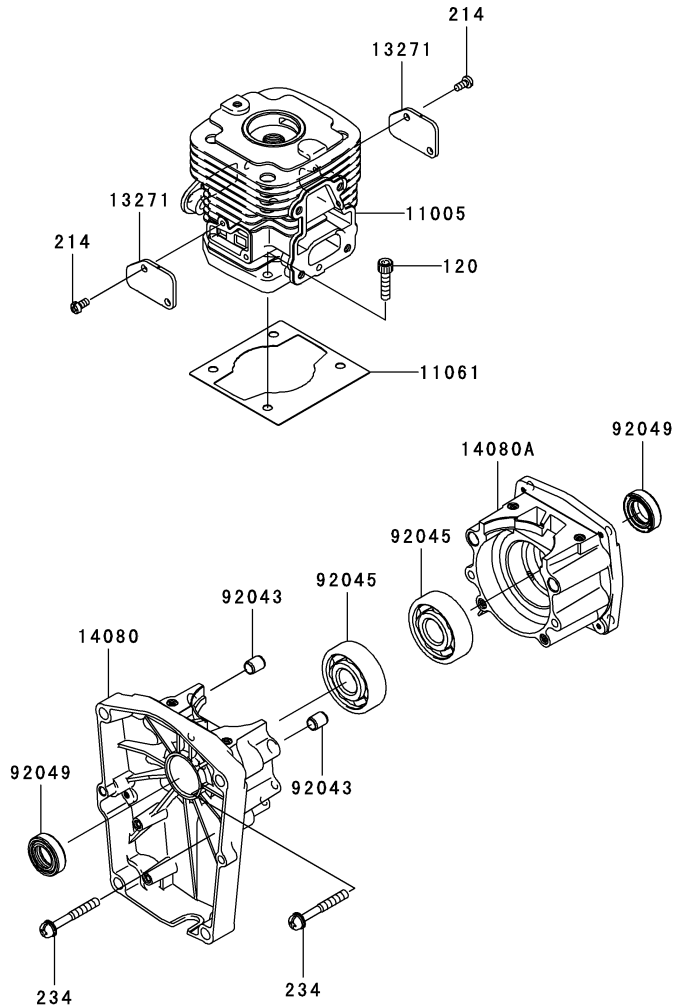

Ref. No.	Part No.	Description	Quantity
11005	11005-2156	CYLINDER-ENGINE	1
11061	11061-2148	GASKET,CYLINDER	1
13271	13271-2250	PLATE	2
14080	14080-2057	CRANKCASE	1
14080A	14080-2058	CRANKCASE	1
92043	92043-1302	PIN	2
92045	92045-2269	BEARING-BALL,6302C3	2
92049	92049-2259	SEAL-OIL,ISCD-15-25-7-F	2
120	120CB0520	BOLT-SOCKET,5X20	4
214	214AA0408	SCREW-PAN+,-,4X8	4
234	234AA0540	SCREW-PAN-WSP+,-,5X40	4

This catalog covers:

TK045D- □ C52

02

This fig. covers:

PISTON/CRANKSHAFT

E0120-A376A

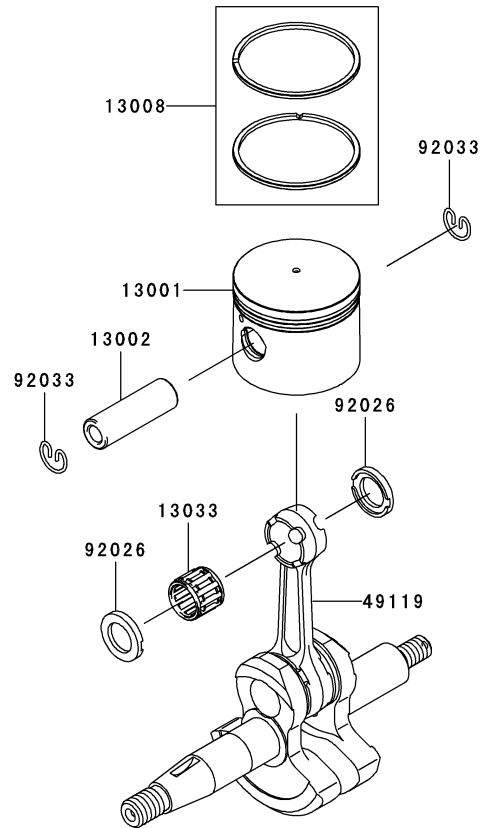

Ref. No.	Part No.	Description	Quantity
13001	13001-2172	PISTON-ENGINE	1
13002	13002-2094	PIN-PISTON	1
13008	13008-6067	RING-SET-PISTON	1
13033	13033-2063	BEARING-SMALL END	1
49119	49119-2224	CRANKSHAFT-ASSY	1
92026	92026-2353	SPACER	2
92033	92033-2058	RING-SNAP	2

This catalog covers:

TK045D- □ C52

This fig. covers:

03 COOLING-EQUIPMENT

E0150-A806A

Ref. No.	Part No.	Description	Quantity
49089	49089-2612	SHROUD-ENGINE	1
49089A	49089-2635	SHROUD-ENGINE	1
241	241AA0510	SCREW-PAN-WP+,5X10	1

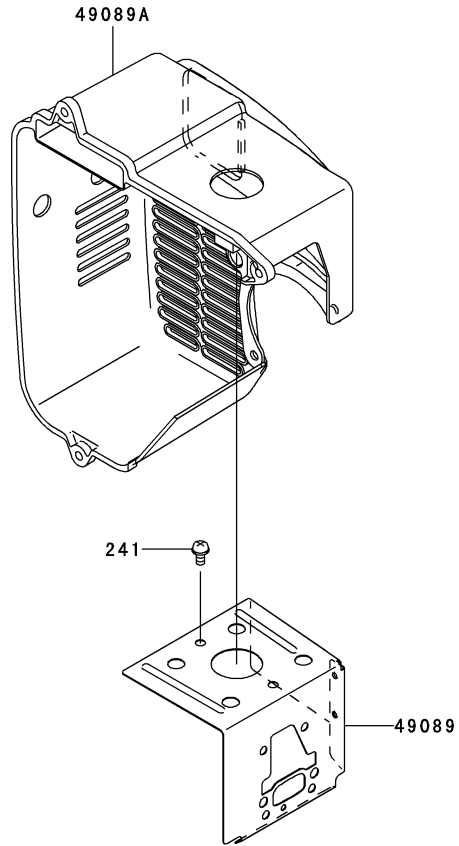

This catalog covers:

TK045D- □ C52

04

This fig. covers:

ELECTRIC-EQUIPMENT

E0160-B076A

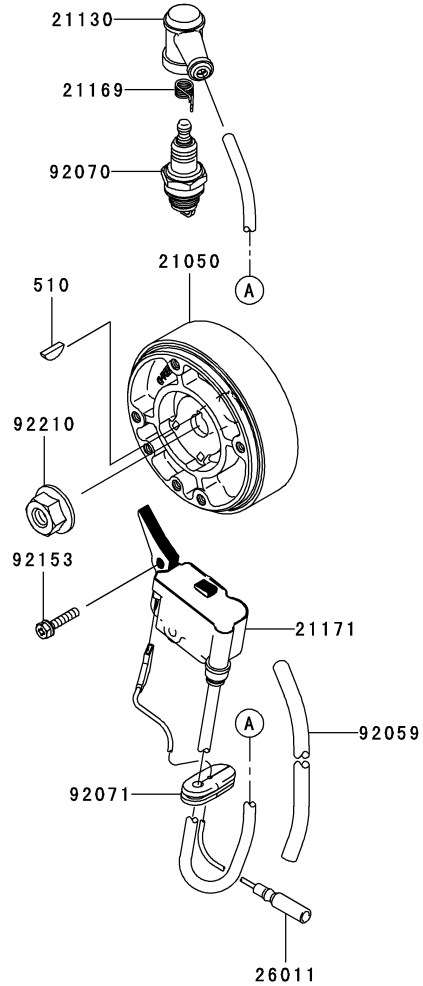

Ref. No.	Part No.	Description	Quantity
21050	21050-2310	FLYWHEEL	1
21130	21130-2056	CAP-SPARK PLUG	1
21169	21169-2051	TERMINAL	1
21171	21171-2248	COIL-ASSY-IGNITION	1
26011	26011-2379	WIRE-LEAD	1
92059	92059-2233	TUBE,6X7.4X300	1
92070	92070-2113	PLUG-SPARK,BPMR7A(NGK),SOLID	1
92071	92071-2164	GROMMET	1
92153	92153-2079	BOLT,4X20	2
92210	92210-1325	NUT,M10	1
510	510A3200	KEY-WOODRUFF	1

This catalog covers:

TK045D- □ C52

05

This fig. covers:

CARBURETOR

E0180-A719A

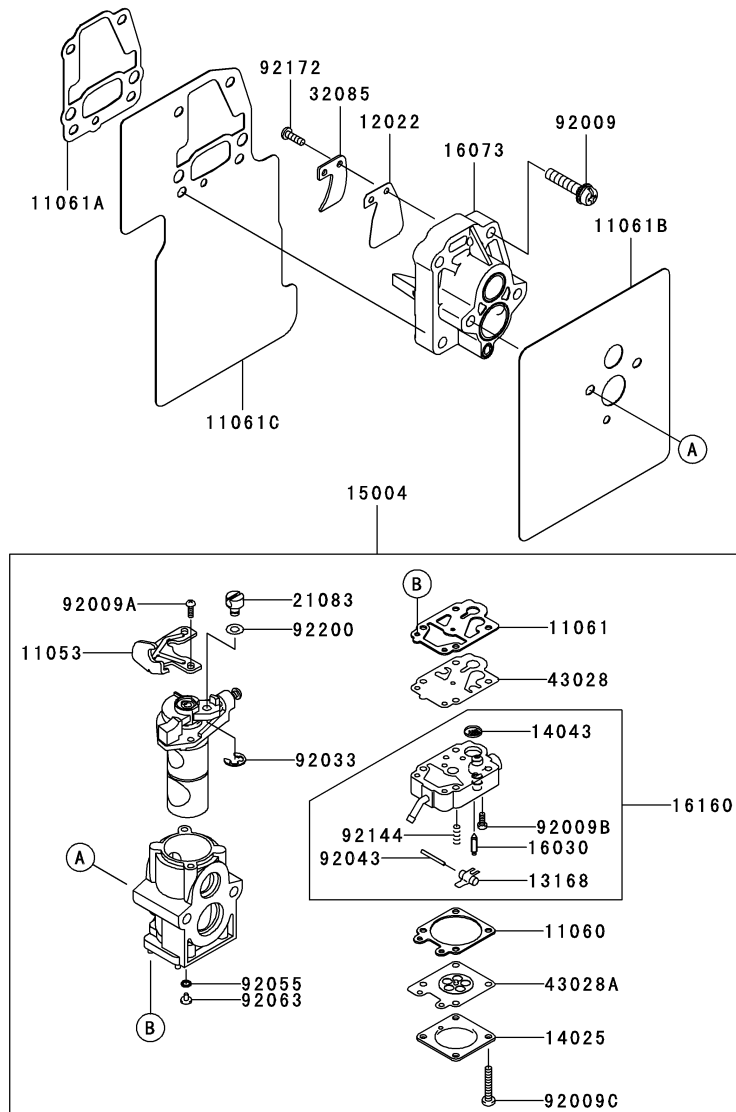

Ref. No.	Part No.	Description	Quantity
11053	11053-2066	BRACKET	1
11060	11060-2456	GASKET	1
11061	11061-2054	GASKET	1
11061A	11061-2150	GASKET,INSULATOR	1
11061B	11061-2160	GASKET,CARBURETOR/INSULATOR	1
11061C	11061-2196	GASKET	1
12022	12022-2059	VALVE-REED	1
13168	16055-2051	LEVER	1
14025	14025-2157	COVER	1
14043	14043-2051	FILTER	1
15004	15004-2034	CARBURETOR-ASSY	1
16030	16030-2078	VALVE-FLOAT	1
16073	16073-2235	INSULATOR	1
16160	16160-2138	BODY	1
21083	21083-2073	ARM	1
32085	32085-2105	STOPPER	1
43028	43028-2067	DIAPHRAGM	1
43028A	43028-2096	DIAPHRAGM	1
92009	92009-2235	SCREW,5X25	4
92009A	92009-2277	SCREW	2
92009B	92009-2336	SCREW	1
92009C	92009-2438	SCREW	4
92033	92033-2078	RING-SNAP	1
92043	92043-2094	PIN	1
92055	92055-2147	RING-O	1
92063	92063-2481	JET-MAIN,#57	1
92144	92144-2308	SPRING	1
92172	92172-2091	SCREW,3X12	1
92200	92200-2074	WASHER	1

This catalog covers:

TK045D- □ C52

06

This fig. covers:

AIR-FILTER/MUFFLER

E0190-A980A

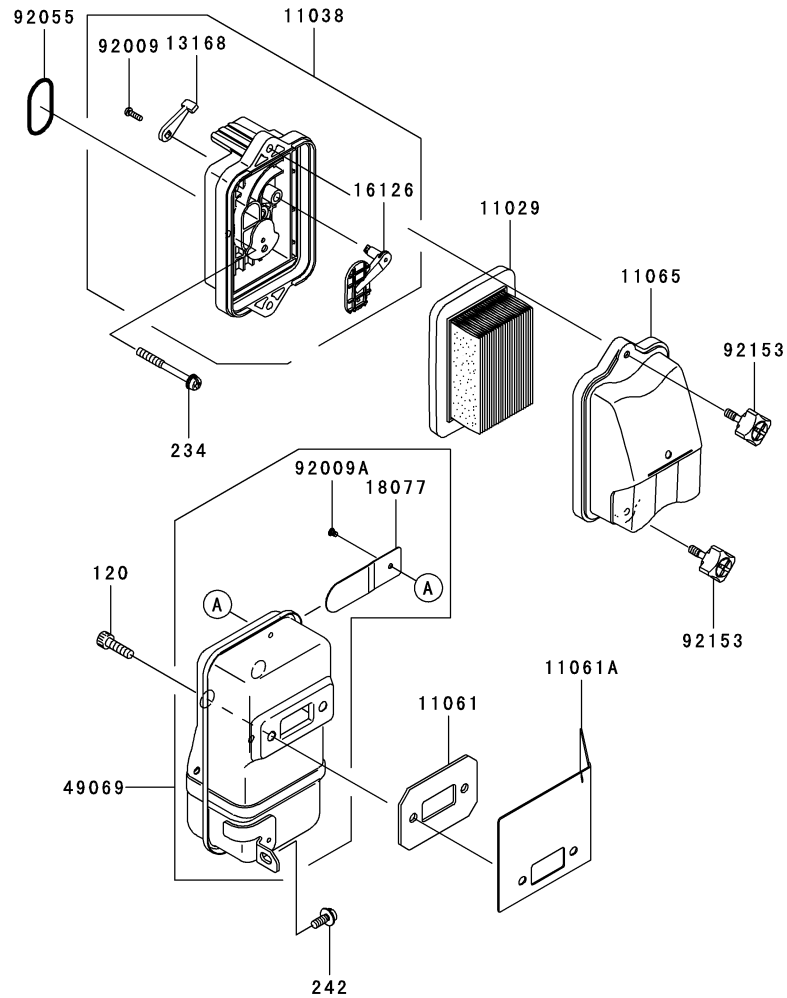

Ref. No.	Part No.	Description	Quantity
11029	11029-2022	ELEMENT-ASSY-AIR FILTER	1
11038	11038-2091	CASE-ASSY-AIR FILTER	1
11061	11061-2186	GASKET	1
11061A	11061-2188	GASKET	1
11065	11065-2119	CAP,AIR FILTER	1
13168	13168-2493	LEVER	1
16126	16126-2241	VALVE	1
18077	18077-2134	ARRESTER-SPARK	1
49069	49069-2417	MUFFLER-ASSY	1
92009	92009-2359	SCREW,3X10	1
92009A	92009-2411	SCREW	1
92055	92055-2205	RING-O,ID=31.2	1
92153	92153-2107	BOLT,5X18	2
120	120CB0620	BOLT-SOCKET,6X20	2
234	234AA0555	SCREW-PAN-WSP+,-,5X55	2
242	242AA0514	SCREW-PAN-WSP+,-,5X14	1

This catalog covers:

TK045D- □ C52

This fig. covers:

07 FUEL-TANK/FUEL-VALVE

E0200-A602A

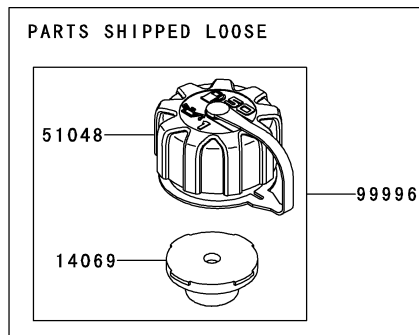
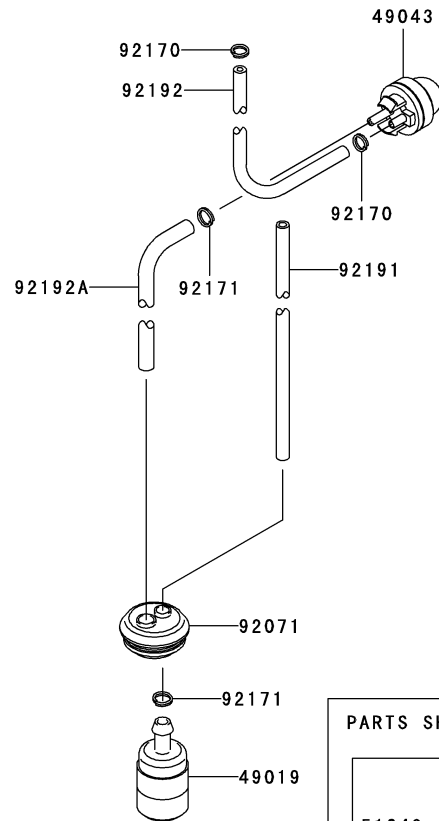

Ref. No.	Part No.	Description	Quantity
14069	14069-2088	BREATHER	1
49019	49019-2085	FILTER-FUEL	1
49043	49043-2073	PUMP-PRIMING,CARBURETOR	1
51048	51048-2083	CAP-ASSY-TANK	1
92071	92071-2142	GROMMET,FUEL TANK	1
92170	92170-2110	CLAMP	2
92171	92171-2073	CLAMP	2
92191	92191-2136	TUBE,3X5X300	1
92192	92192-2086	TUBE,2.3X5X93	1
92192A	92192-2150	TUBE,3X6X160	1
99996	99996-6089	CAP-TANK & BREATHER,ASSY	1

This catalog covers:

TK045D- □ C52

08

This fig. covers:

STARTER

E0210-A360A

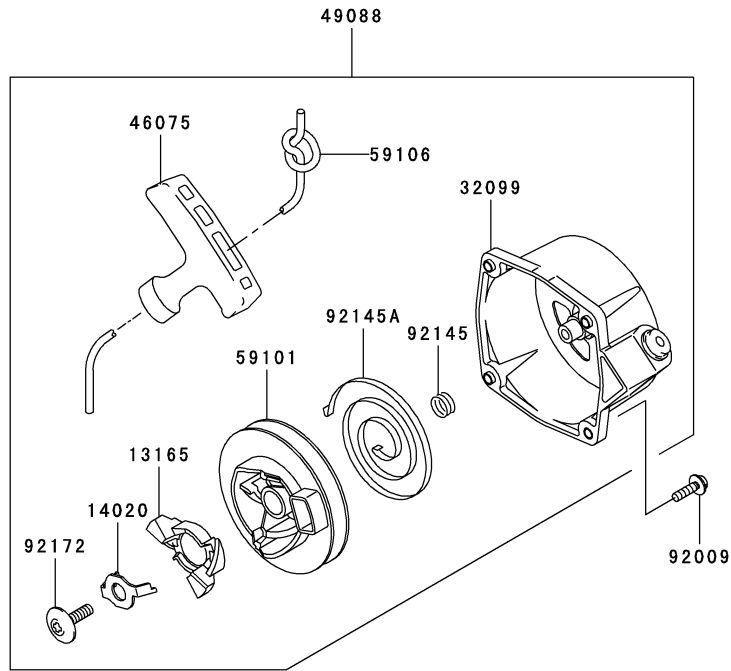

Ref. No.	Part No.	Description	Quantity
13165	13165-2101	PAWL,STARTER-RECOIL	1
14020	14020-2113	RETAINER	1
32099	32099-2400	CASE,STARTER-RECOIL	1
46075	46075-2153	GRIP,STARTER-RECOIL	1
49080	49080-2198	PULLEY-STARTING	1
49088	49088-2540	STARTER-RECOIL	1
59101	59101-2117	REEL,STARTER-RECOIL	1
59106	59106-2174	ROPE,3.5X1000	1
92009	92009-2386	SCREW,4X16	4
92145	92145-2142	SPRING	1
92145A	92145-2143	SPRING,RECOIL	1
92172	92172-2083	SCREW	1
92210	92210-2094	NUT	1

This catalog covers:

TK045D- □ C52

09

This fig. covers:

LABEL

F0290-B350A

Ref. No.	Part No.	Description	Quantity
56031	56031-2468	LABEL-MANUAL	1
56070	56070-2020	LABEL-WARNING	1
56070A	56070-2074	LABEL-WARNING	1

56031

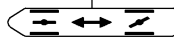

56070



56070A

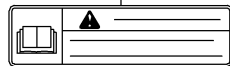

This catalog covers:

TK045D- □ C52

This fig. covers:

PART NAME INDEX

AIR-FILTER/MUFFLER.....	06
CARBURETOR.....	05
COOLING-EQUIPMENT.....	03
CYLINDER/CRANKCASE	01
ELECTRIC-EQUIPMENT.....	04
FUEL-TANK/FUEL-VALVE.....	07
LABEL.....	09
PISTON/CRANKSHAFT	02
STARTER.....	08

