

This catalog covers:

TJ045E-□C59

This fig. covers:

TITLE

PARTS CATALOG

2-STROKE ENGINE

TJ045E

PRODUCT CODE	NOTE
TJ045E-AC59	BRUSH-CUTTER



This catalog covers:
TJ045E-□C59

PARTS CATALOG INTRODUCTION

This parts catalog lists parts and sub-assemblies provided as service parts. When it becomes necessary to replace parts, always use KAWASAKI GENUINE PARTS which have passed strict inspection which guarantees quality and performance.

1. HOW TO ORDER PARTS

- When ordering the parts, be sure to use the parts catalog corresponding to the product code. Check the product revision codes on the product and the catalog.
 Product Code (example) : FA130D-AA00
└──────────────────┘
 Product Revision Code
- Specify the part code (all digits) exactly as listed in this catalog on your parts order.
- The parts not shown in the illustrations of this catalog are not sold separately; only the complete units or next higher assemblies illustrated are supplied as the service parts.

2. EXPLANATION OF PARTS CATALOG FORMAT

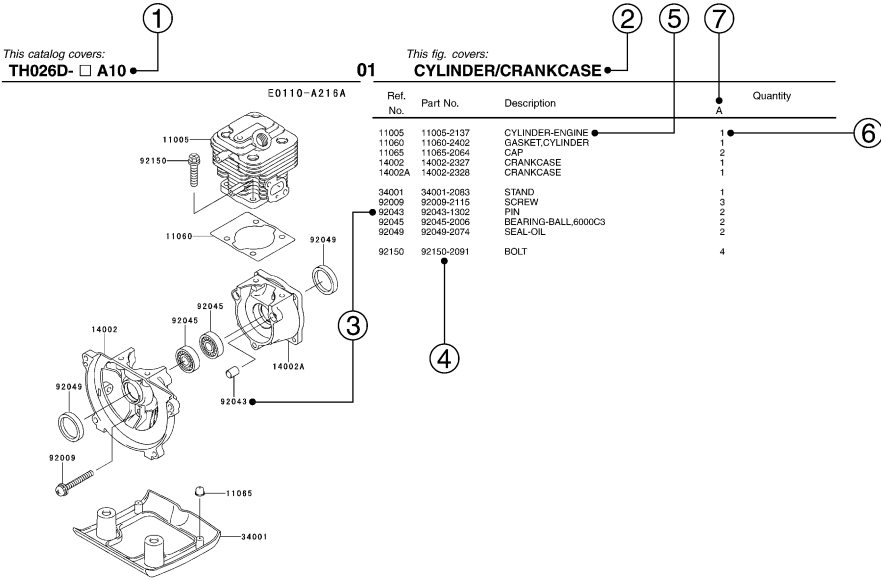

- Product Code**
 This code describes the product code covered by this catalog. The product revision code, which is a part of the product code, is omitted.
- Part Group Title**
 This title is the representative name for the group of parts illustrated on the page.
- Reference Number**
 The reference numbers are shown on the illustration and the list as the link between them.

This fig. covers:
PARTS LIST INFOMATION

4) Part Number

This is the key of your parts ordering. Three kinds of part number are used in this catalog.

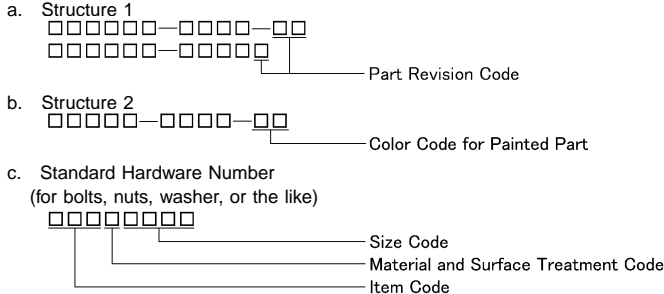

5) Description and Additional Information

The part name, the location, the size, and the serial number as additional information, etc. are described here. Use them to find out and check the part required. When a part number is changed without change of the product revision code and the changed parts are not interchangeable, the serial number of the product is noted as follows;

- (FA130 - 100001) : Affected units are from beginning of the product of the product code up to and including this serial number.
- (FA130 - 100002 -) : Affected units are from this serial number and above.
- (FA130 - 100002 - FA130 - 110001) : Affected units are in this serial number range.

6) Quantity

The figure shows quantity of the part required at the indicated position on the illustration and for the specified product revision code. The asterisk (*) on this column means the part can be used as the substitute on the product and is supplied until the stock is exhausted. Note:Some small parts will be supplied by units.

Example: If six (6) bolts are ordered and the minimum quantity per unit is five (5), two (2), units of the bolt will be delivered.

7) Product Revision Code

This Code indicates an important change which affects the service parts interchangeability.

3. ABBREVIATIONS

#.....Number	FR.....Front	RH.....Right Hand
&.....And	G.....Gram	RPM.....Revolutions Per Minute
(+).....Plus	HEX.....Hexagonal	RR.....Rear
(-).....Minus	ID=.....Inside Diameter	STD.....Standard
2ND.....Second	IN.....Inch	T.....Teeth
3RD.....Third	L=.....Length	T=.....Thickness
4TH.....Fourth	LH.....Left Hand	U/S.....Under Size
A.....Ampere	LWR.....Lower	UPP.....Upper
AR.....As Required	MM.....Millimeter	V.....Volt
ASSY.....Assembly	O/S.....Over Size	W.....Watt
CNT.....Center	OD=.....Outside Diameter	
COMP.....Complete	REF.....Reference	

This catalog covers:

TJ045E- □ C59

01

This fig. covers:

CYLINDER/CRANKCASE

E0110-A586A

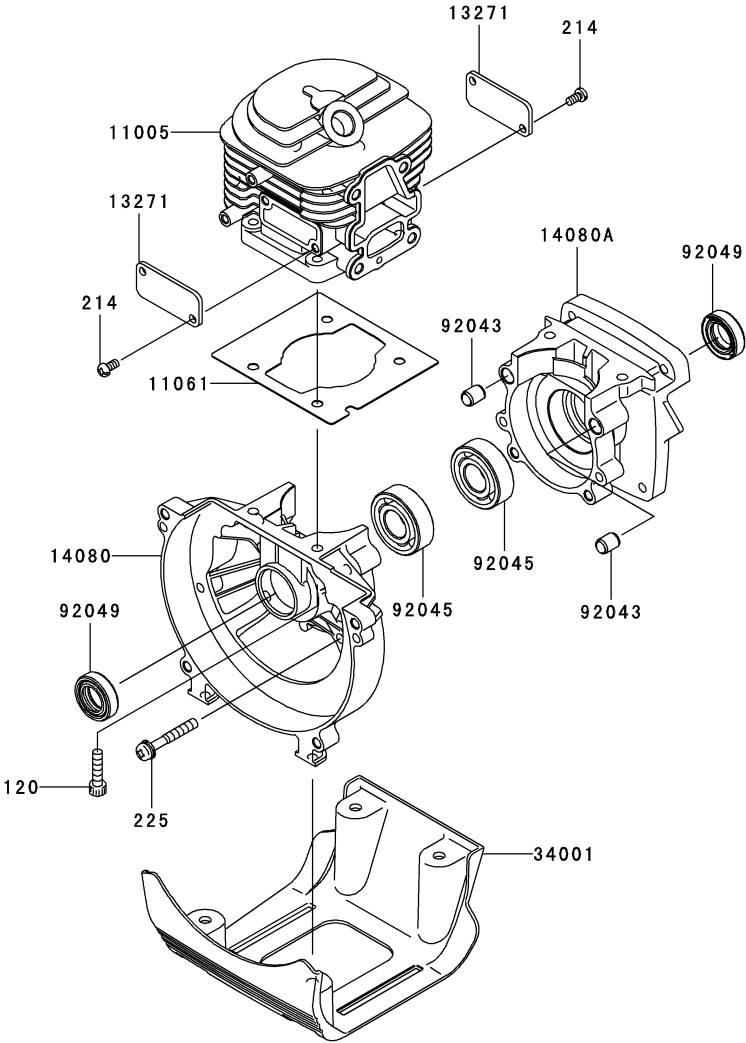

Ref. No.	Part No.	Description	Quantity
11005	11005-2159	CYLINDER-ENGINE	1
11061	11061-2173	GASKET,CYLINDER	1
13271	13271-2262	PLATE	2
14080	14080-2062	CRANKCASE	1
14080A	14080-2063	CRANKCASE	1
34001	34001-2089	STAND	1
92043	92043-1302	PIN	2
92045	92045-2279	BEARING-BALL,6202C3	2
92049	92049-2259	SEAL-OIL,ISCD-15-25-7-F	2
120	120CB0520	BOLT-SOCKET,5X20	4
214	214AA0408	SCREW-PAN+,4X8	4
225	225AA0535	SCREW-PAN-WSP-CROS,5X35	4

This catalog covers:

TJ045E- □ C59

02

This fig. covers:

PISTON/CRANKSHAFT

E0120-A373A

Ref. No.	Part No.	Description	Quantity
13001	13001-2166	PISTON-ENGINE	1
13002	13002-2067	PIN-PISTON	1
13008	13008-6067	RING-SET-PISTON	1
13033	13033-2063	BEARING-SMALL END	1
49119	49119-2231	CRANKSHAFT-ASSY	1
92026	92026-2353	SPACER	2
92033	92033-2058	RING-SNAP	2

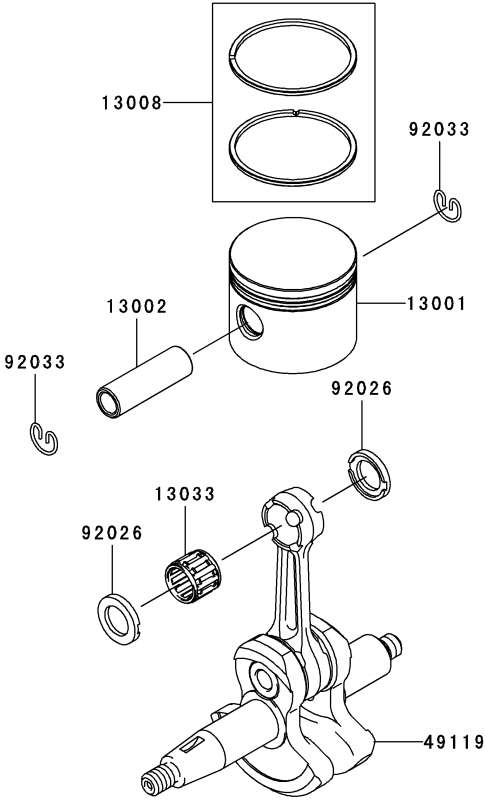

This catalog covers:

TJ045E- □ C59

03

This fig. covers:

COOLING-EQUIPMENT

E0150-A827A

Ref. No.	Part No.	Description	Quantity
49089	49089-2659	SHROUD-ENGINE	1
59066	59066-2811-754	HOUSING-FAN	1
92172	92172-2060	SCREW,4X10	2
233	233AA0516	SCREW-PAN-WP+-.5X16	4

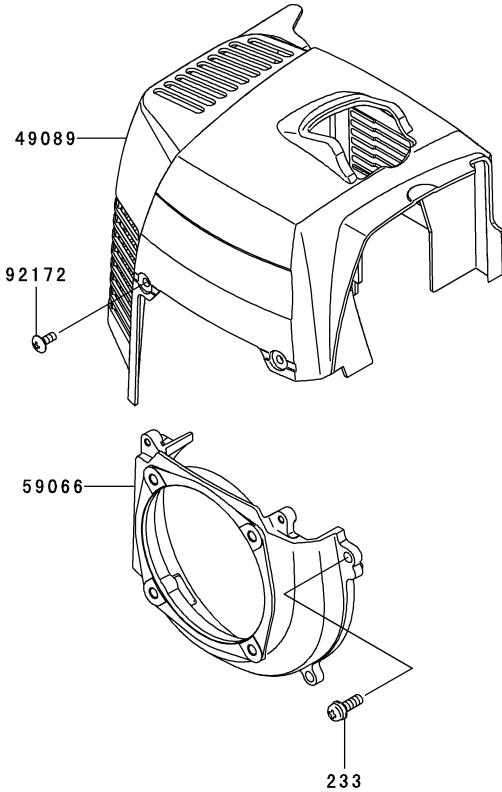

This catalog covers:

TJ045E- □ C59

04

This fig. covers:

ELECTRIC-EQUIPMENT

E0160-B242A

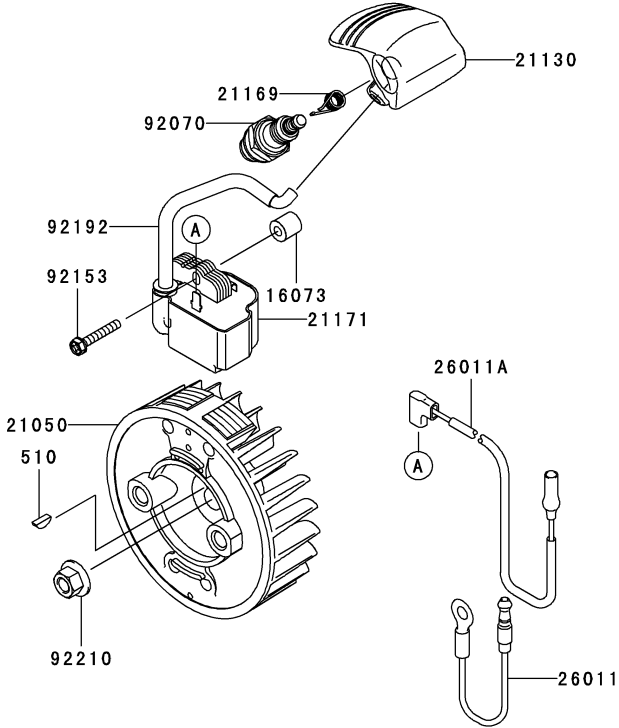

Ref. No.	Part No.	Description	Quantity
16073	16073-2220	INSULATOR	2
21050	21050-2313	FLYWHEEL	1
21130	21130-2072	CAP-SPARK PLUG	1
21169	21169-2051	TERMINAL	1
21171	21171-2250	COIL-ASSY-IGNITION	1
26011	26011-2113	WIRE-LEAD	1
26011A	26011-2361	WIRE-LEAD,L=230	1
92070	92070-2107	PLUG-SPARK,BPMR7A(NGK),SOLID	1
92153	92153-2135	BOLT,4X25	2
92192	92192-2165	TUBE,6X6.6X80	1
92210	92210-2101	NUT,M8	1
510	510A3100	KEY-WOODRUFF	1

This catalog covers:
TJ045E- □ C59

This fig. covers:
05 CARBURETOR

E0180-A745A

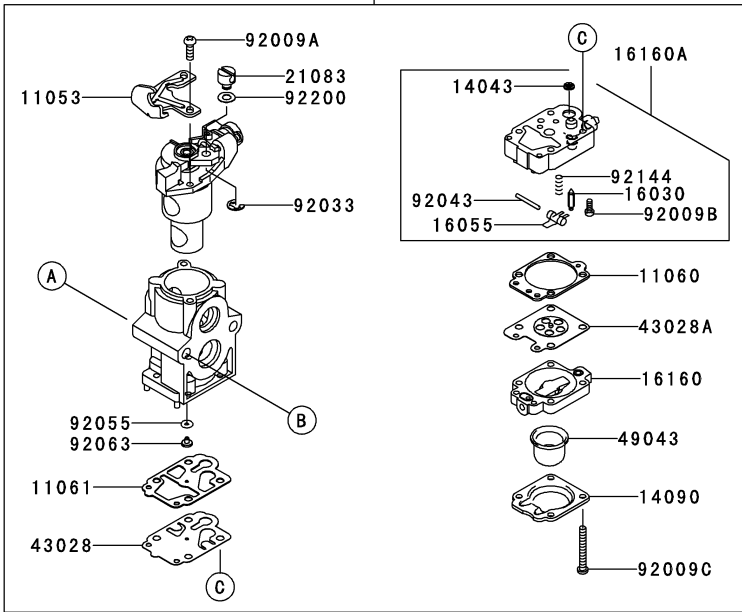
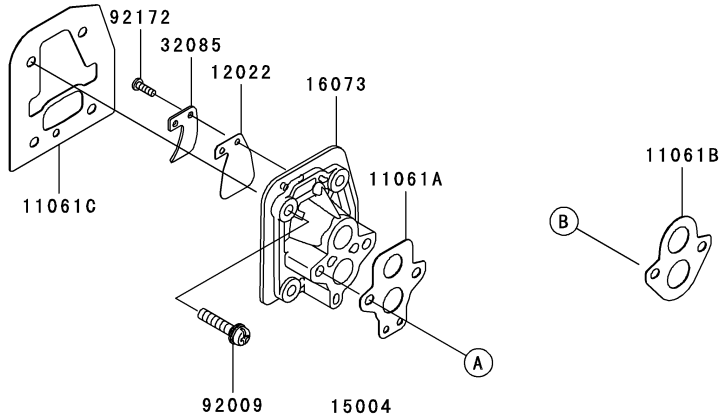

Ref. No.	Part No.	Description	Quantity
11053	11053-2066	BRACKET	1
11060	11060-2111	GASKET	1
11061	11061-2054	GASKET	1
11061A	11061-2175	GASKET,CARBURETOR-INSULATOR	1
11061B	11061-2176	GASKET	1
11061C	11061-2178	GASKET,CYLINDER-INSULATOR	1
12022	12022-2059	VALVE-REED	1
14043	14043-2051	FILTER	1
14090	14090-2017	COVER,PRIMER PUMP	1
15004	15004-2060	CARBURETOR-ASSY	1
16030	16030-2078	VALVE-FLOAT	1
16055	16055-2051	LEVER	1
16073	16073-2236	INSULATOR	1
16160	16160-2089	BODY	1
16160A	16160-2103	BODY	1
21083	21083-2073	ARM	1
32085	32085-2105	STOPPER	1
43028	43028-2067	DIAPHRAGM	1
43028A	43028-2096	DIAPHRAGM	1
49043	49043-2067	PUMP-PRIMING	1
92009	92009-2235	SCREW,5X25	4
92009A	92009-2277	SCREW	2
92009B	92009-2336	SCREW	1
92009C	92009-2337	SCREW	4
92033	92033-2078	RING-SNAP	1
92043	92043-2094	PIN	1
92055	92055-2147	RING-O	1
92063	92063-2483	JET-MAIN,#40	1
92144	92144-2308	SPRING	1
92172	92172-2091	SCREW,3X12	1
92200	92200-2074	WASHER	1

This catalog covers:
TJ045E- □ C59

This fig. covers:
06 AIR-FILTER/MUFFLER

E0190-B018A

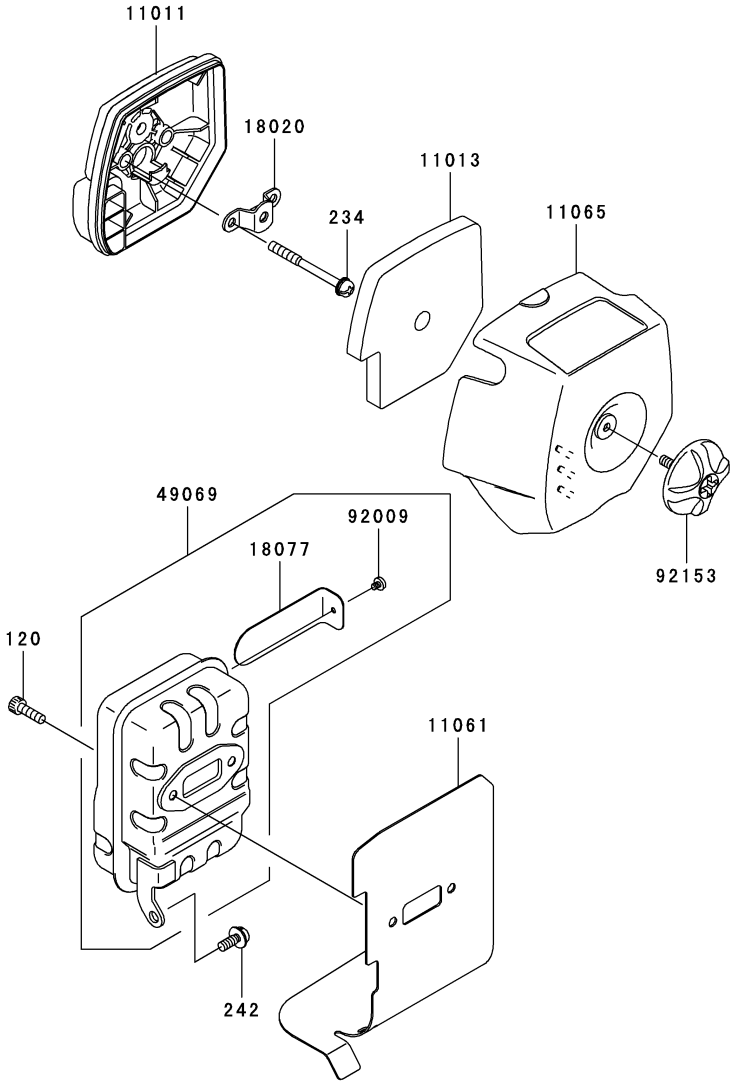

Ref. No.	Part No.	Description	Quantity
11011	11011-2362	CASE-AIR FILTER	1
11013	11013-2226	ELEMENT-AIR FILTER	1
11061	11061-2174	GASKET,MUFFLER	1
11065	11065-2123	CAP	1
18020	18020-2091	BAFFLE	1
18077	18077-2137	ARRESTER-SPARK	1
49069	49069-2434	MUFFLER-ASSY	1
92009	92009-2411	SCREW	1
92153	92153-2128	BOLT	1
120	120CB0516	BOLT-SOCKET,5X16	2
234	234AA0555	SCREW-PAN-WSP+,,5X55	2
242	242AA0514	SCREW-PAN-WSP+,,5X14	1

This catalog covers:

TJ045E- □ C59

07

This fig. covers:

FUEL-TANK/FUEL-VALVE

E0200-A641A

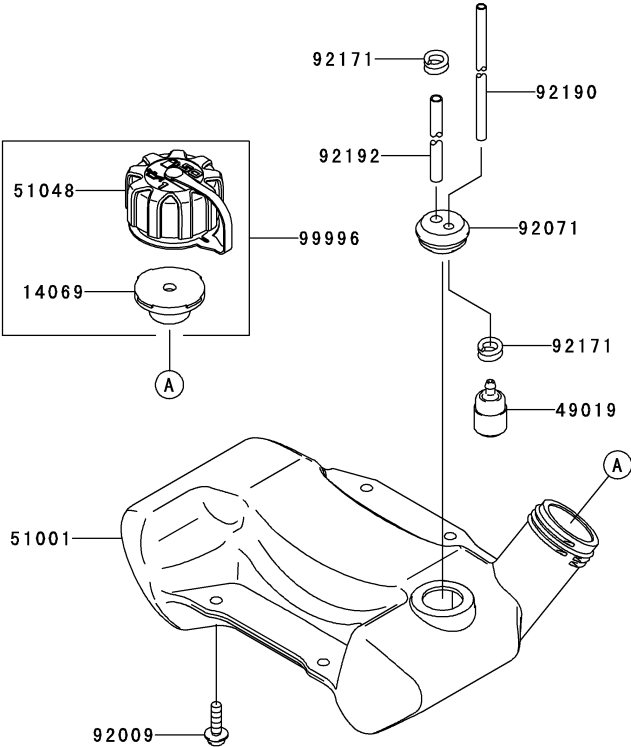

Ref. No.	Part No.	Description	Quantity
14069	14069-2088	BREATHER	1
49019	49019-2114	FILTER-FUEL	1
51001	51001-2324	TANK-COMP-FUEL	1
51048	51048-2083	CAP-ASSY-TANK	1
92009	92009-2383	SCREW,5X20	4
92071	92071-2142	GROMMET,FUEL TANK	1
92171	92171-2073	CLAMP	2
92190	92190-2157	TUBE,3X5X200	1
92192	92192-2149	TUBE,3X6X105	1
99996	99996-6089	CAP-TANK & BREATHER,ASSY	1

This catalog covers:

TJ045E- □ C59

08

This fig. covers:

STARTER

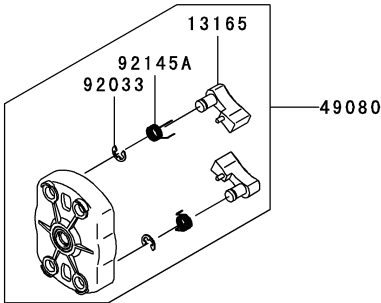
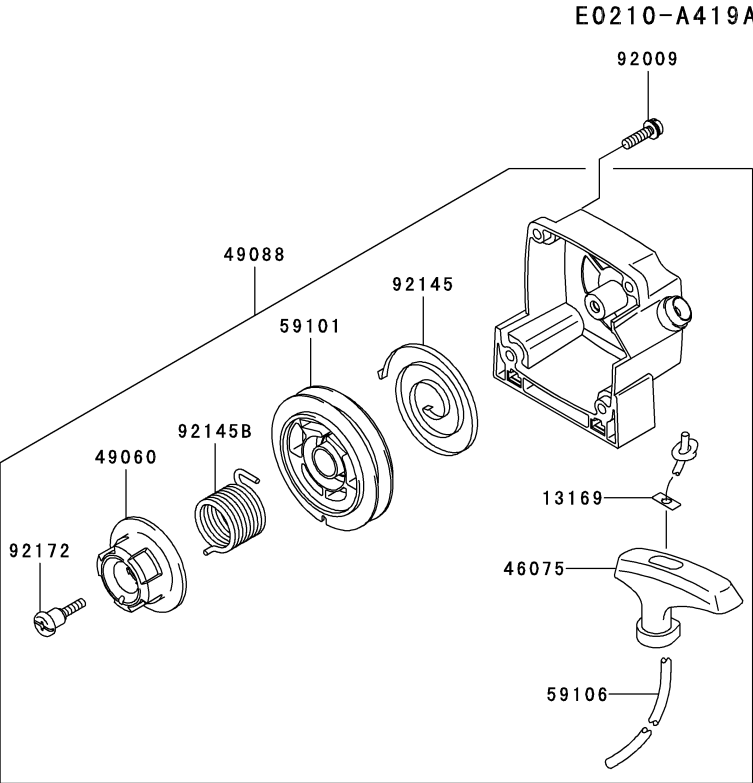

Ref. No.	Part No.	Description	Quantity
13165	13165-2107	PAWL	2
13169	13169-2386	PLATE,RECOIL STARTER	1
46075	46075-2129	GRIP,RECOIL STARTER	1
49060	49060-2065	CAM,STARTER-RECOIL	1
49080	49080-2205	PULLEY-STARTING	1
49088	49088-2559	STARTER-RECOIL	1
59101	59101-2120	REEL,STARTER-RECOIL	1
59106	59106-2064	ROPE,3.8X950	1
92009	92009-2249	SCREW,5X20	4
92033	92033-2010	RING-SNAP	2
92145	92145-2112	SPRING,SPIRAL	1
92145A	92145-2148	SPRING	2
92145B	92145-2150	SPRING	1
92172	92172-2100	SCREW	1

This catalog covers:

TJ045E- □ C59

09

This fig. covers:

P.T.O-EQUIPMENT

E0220-A017A

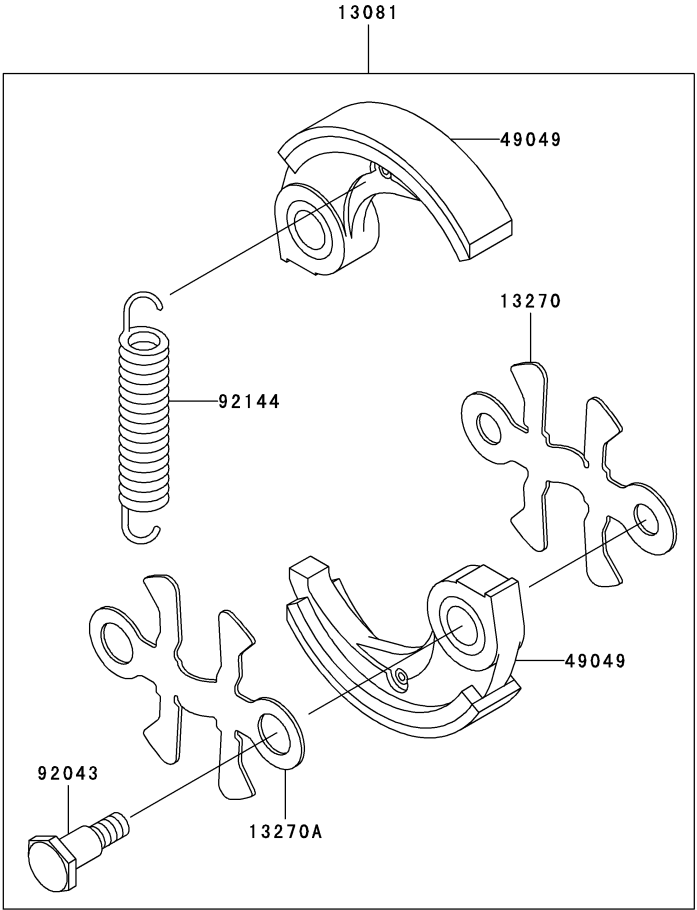

Ref. No.	Part No.	Description	Quantity
13081	13081-2224	CLUTCH-ASSY	1
13270	13270-2118	PLATE	1
13270A	13270-2119	PLATE	1
49049	49049-2098	SHOE-CLUTCH	2
92043	92043-2210	PIN,CLUTCH	2
92144	92144-2373	SPRING	1

This catalog covers:

TJ045E- □ C59

10

This fig. covers:

LABEL

F0290-B422A

Ref. No.	Part No.	Description	Quantity
56039	56039-2970	LABEL-PRODUCT	1
56070	56070-2020	LABEL-WARNING	1
56080	56080-2413	LABEL-BRAND	1

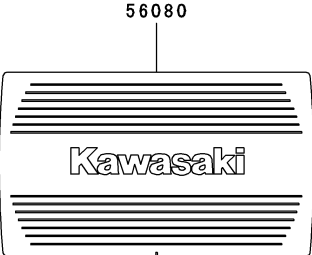
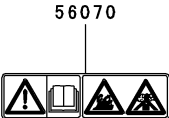

This catalog covers:

TJ045E- □ C59

This fig. covers:

PART NAME INDEX

AIR-FILTER/MUFFLER.....06
CARBURETOR.....05
COOLING-EQUIPMENT.....03
CYLINDER/CRANKCASE01
ELECTRIC-EQUIPMENT.....04
FUEL-TANK/FUEL-VALVE.....07
LABEL.....10
P.T.O-EQUIPMENT.....09
PISTON/CRANKSHAFT02
STARTER.....08

