

This catalog covers:

TJ027E-□C51

This fig. covers:

TITLE

PARTS CATALOG

2-STROKE ENGINE

TJ027E

PRODUCT CODE	NOTE
TJ027E-AC51	BRUSH-CUTTER (VS255)



This catalog covers:
TJ027E-□C51

This fig. covers:
PARTS LIST INFOMATION

PARTS CATALOG INTRODUCTION

This parts catalog lists parts and sub-assemblies provided as service parts. When it becomes necessary to replace parts, always use KAWASAKI GENUINE PARTS which have passed strict inspection which guarantees quality and performance.

1. HOW TO ORDER PARTS

- When ordering the parts, be sure to use the parts catalog corresponding to the product code. Check the product revision codes on the product and the catalog.
 Product Code (example) : FA130D-AA00
└──────────────────┘
 Product Revision Code
- Specify the part code (all digits) exactly as listed in this catalog on your parts order.
- The parts not shown in the illustrations of this catalog are not sold separately; only the complete units or next higher assemblies illustrated are supplied as the service parts.

2. EXPLANATION OF PARTS CATALOG FORMAT

This catalog covers: **TH026D-□A10** This fig. covers: **01 CYLINDER/CRANKCASE**

Ref. No.	Part No.	Description	Quantity
11005	11005-2137	CYLINDER-ENGINE	1
11060	11060-2402	GASKET,CYLINDER	1
11065	11065-2064	CAP	2
14002	14002-2327	CRANKCASE	1
14002A	14002-2328	CRANKCASE	1
34001	34001-2083	STAND	1
92009	92009-2115	SCREW	3
92045	92045-1502	PIN	2
92045	92045-2006	BEARING-BALL,6000C3	2
92049	92049-2074	SEAL-OIL	2
92150	92150-2091	BOLT	4

1 JUN.03.1999 ED110-A216A

1) Product Code

This code describes the product code covered by this catalog. The product revision code, which is a part of the product code, is omitted.

2) Part Group Title

This title is the representative name for the group of parts illustrated on the page.

3) Reference Number

The reference numbers are shown on the illustration and the list as the link between them.

4) Part Number

This is the key of your parts ordering. Three kinds of part number are used in this catalog.

- Structure 1
 □□□□□□-□□□□-□□
 □□□□□□-□□□□□□
└──────────────────┘
 Part Revision Code
- Structure 2
 □□□□□□-□□□□-□□
└──────────────────┘
 Color Code for Painted Part
- Standard Hardware Number
 (for bolts, nuts, washer, or the like)
 □□□□□□□□
└──────────┘ Size Code
└──────────┘ Material and Surface Treatment Code
└──────────┘ Item Code

5) Description and Additional Information

The part name, the location, the size, and the serial number as additional information, etc. are described here. Use them to find out and check the part required.

When a part number is changed without change of the product revision code and the changed parts are not interchangeable, the serial number of the product is noted as follows;

- (- FA130 - 100001) : Affected units are from beginning of the product of the product code up to and including this serial number.
- (FA130 - 100002 -) : Affected units are from this serial number and above.
- (FA130 - 100002 - FA130 - 110001) : Affected units are in this serial number range.

6) Quantity

The figure shows quantity of the part required at the indicated position on the illustration and for the specified product revision code.

The asterisk (*) on this column means the part can be used as the substitute on the product and is supplied until the stock is exhausted.

Note:Some small parts will be supplied by units.

Example: If six (6) bolts are ordered and the minimum quantity per unit is five (5), two (2), units of the bolt will be delivered.

7) Product Revision Code

This Code indicates an important change which affects the service parts interchangeability.

3. ABBREVIATIONS

#.....Number	FR.....Front	RH.....Right Hand
&.....And	G.....Gram	RPM.....Revolutions Per Minute
(+).....Plus	HEX.....Hexagonal	RR.....Rear
(-).....Minus	ID=.....Inside Diameter	STD.....Standard
2ND.....Second	IN.....Inch	T.....Teeth
3RD.....Third	L=.....Length	T=.....Thickness
4TH.....Fourth	LH.....Left Hand	U/S.....Under Size
A.....Ampere	LWR.....Lower	UPP.....Upper
AR.....As Required	MM.....Millimeter	V.....Volt
ASSY.....Assembly	O/S.....Over Size	W.....Watt
CNT.....Center	OD=.....Outside Diameter	
COMP.....Complete	REF.....Reference	

This catalog covers:

TJ027E- **C51**

This fig. covers:

01 CYLINDER/CRANKCASE

E0110-A571A

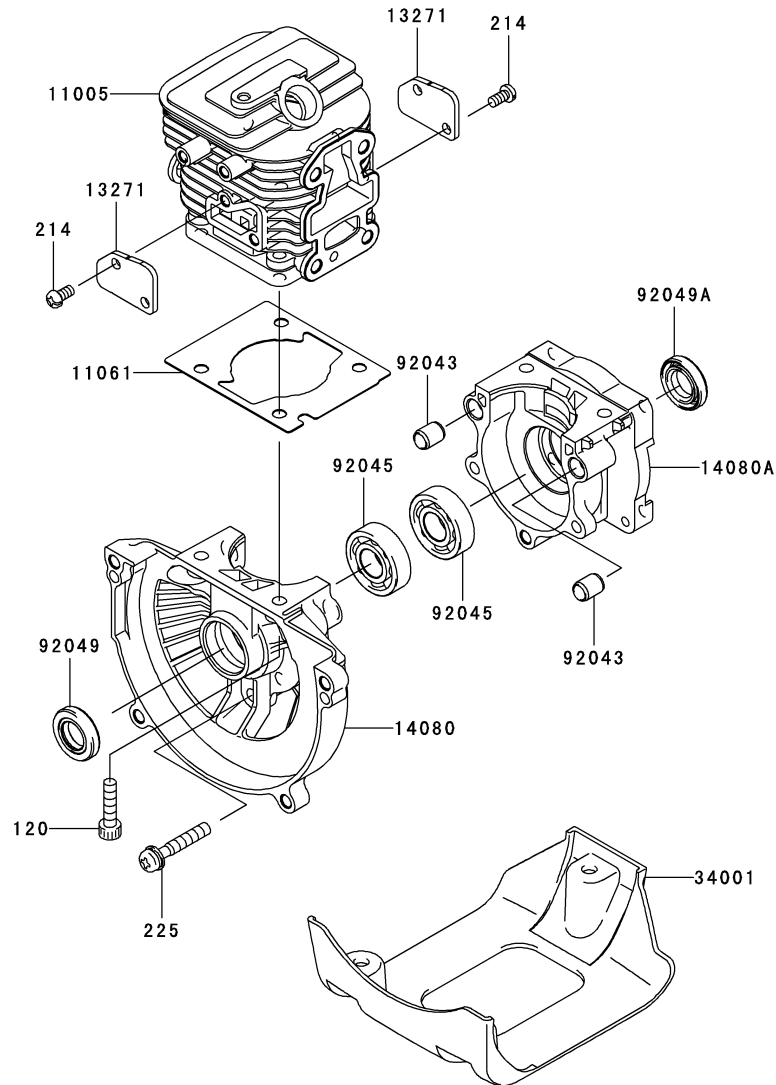

Ref. No.	Part No.	Description	Quantity
11005	11005-2162	CYLINDER-ENGINE	1
11061	11061-2169	GASKET,CYLINDER	1
13271	13271-2261	PLATE	2
14080	14080-2060	CRANKCASE	1
14080A	14080-2061	CRANKCASE	1
34001	34001-2088	STAND	1
92043	92043-1302	PIN	2
92045	92045-2278	BEARING-BALL,6001C3	2
92049	92049-2253	SEAL-OIL,ISCD12X22X4.5	1
92049A	92049-2267	SEAL-OIL,ISCD 12X22X4.5F	1
120	120CB0520	BOLT-SOCKET,5X20	4
214	214AA0408	SCREW-PAN+-,4X8	4
225	225AA0530	SCREW-PAN-WSP-CROS,5X30	3

This catalog covers:

TJ027E- □ C51

02

This fig. covers:

PISTON/CRANKSHAFT

E0120-A364A

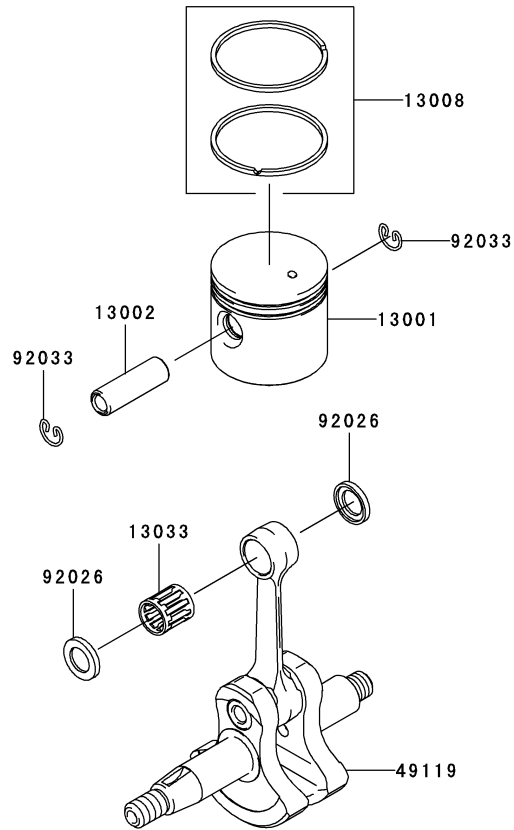

Ref. No.	Part No.	Description	Quantity
13001	13001-2173	PISTON-ENGINE	1
13002	13002-2058	PIN-PISTON	1
13008	13008-6046	RING-SET-PISTON	1
13033	13033-2064	BEARING-SMALL END	1
49119	49119-2230	CRANKSHAFT-ASSY	1
92026	92026-2354	SPACER	2
92033	92033-2191	RING-SNAP	2

This catalog covers:

TJ027E- □ C51

This fig. covers:

03 COOLING-EQUIPMENT

E0150-A816A

Ref. No.	Part No.	Description	Quantity
39156	39156-2084	PAD	1
49089	49089-2630	SHROUD-ENGINE	1
59066	59066-2796	HOUSING-FAN	1
92172	92172-2060	SCREW,4X10	2
233	233AA0516	SCREW-PAN-WP+-.5X16	4

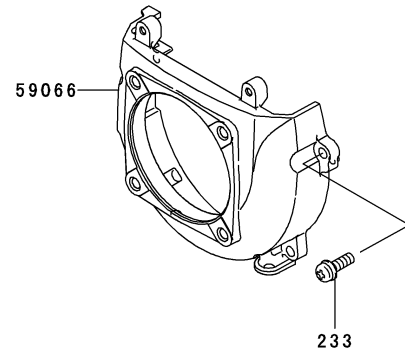
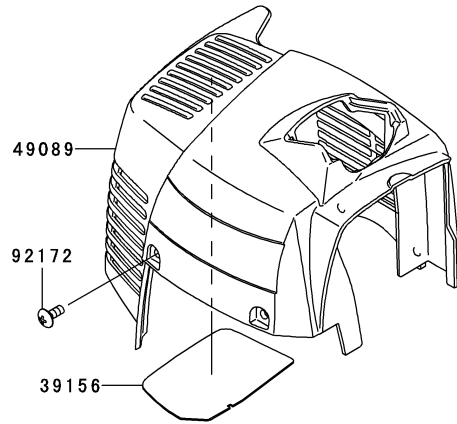

This catalog covers:

TJ027E- □ C51

This fig. covers:

04 ELECTRIC-EQUIPMENT

E0160-B179E

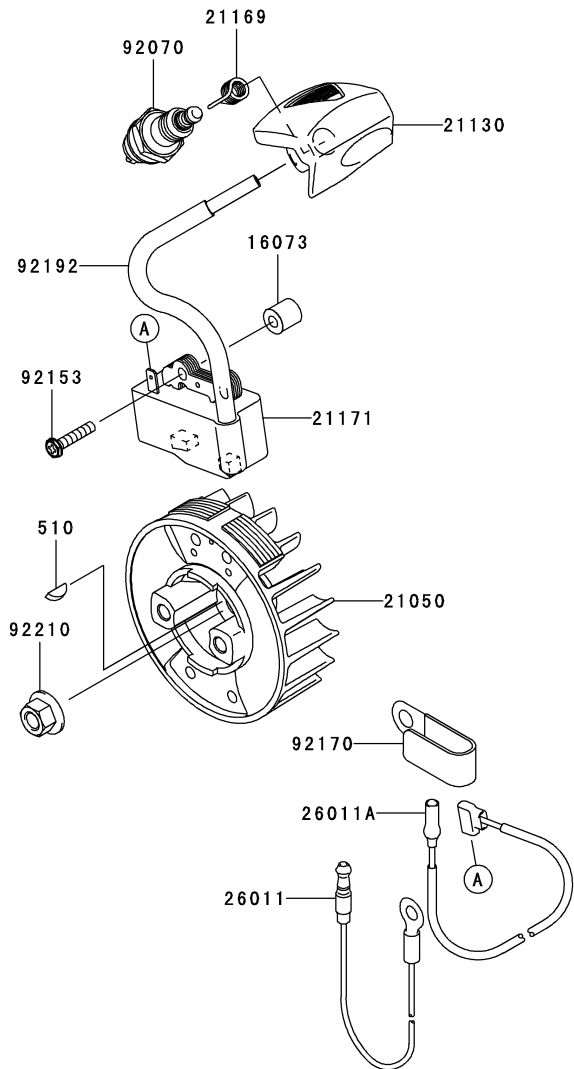

Ref. No.	Part No.	Description	Quantity
16073	16073-2220	INSULATOR	2
21050	21050-2316	FLYWHEEL	1
21130	21130-2071	CAP-SPARK PLUG	1
21169	21169-2075	TERMINAL	1
21171	21171-2256	COIL-ASSY-IGNITION	1
26011	26011-2113	WIRE-LEAD	1
26011A	26011-2361	WIRE-LEAD,L=230	1
92070	92070-2107	PLUG-SPARK,BPMR7A(NGK),SOLID	1
92153	92153-2134	BOLT,4X20	2
92170	92170-2041	CLAMP	1
92192	92192-2135	TUBE	1
92210	92210-2101	NUT,M8	1
510	510A3100	KEY-WOODRUFF	1

This catalog covers:

TJ027E- □ C51

This fig. covers:

06 AIR-FILTER/MUFFLER

E0190-B001B

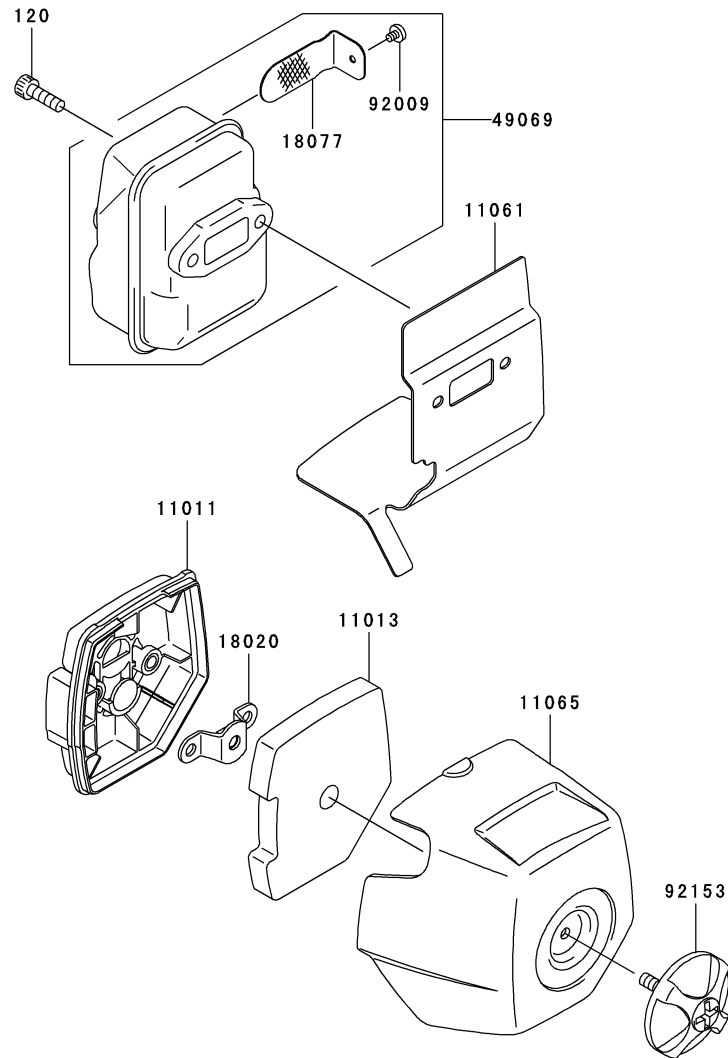

Ref. No.	Part No.	Description	Quantity
11011	11011-2361	CASE-AIR FILTER	1
11013	11013-2224	ELEMENT-AIR FILTER	1
11061	11061-2185	GASKET,MUFFLER	1
11065	11065-2128	CAP	1
18020	18020-2091	BAFFLE	1
18077	18077-2136	ARRESTER-SPARK	1
49069	49069-2429	MUFFLER-ASSY	1
92009	92009-2411	SCREW	1
92153	92153-2128	BOLT	1
120	120CB0516	BOLT-SOCKET,5X16	2

This catalog covers:

TJ027E- □ C51

This fig. covers:

07 FUEL-TANK/FUEL-VALVE

E0200-A629A

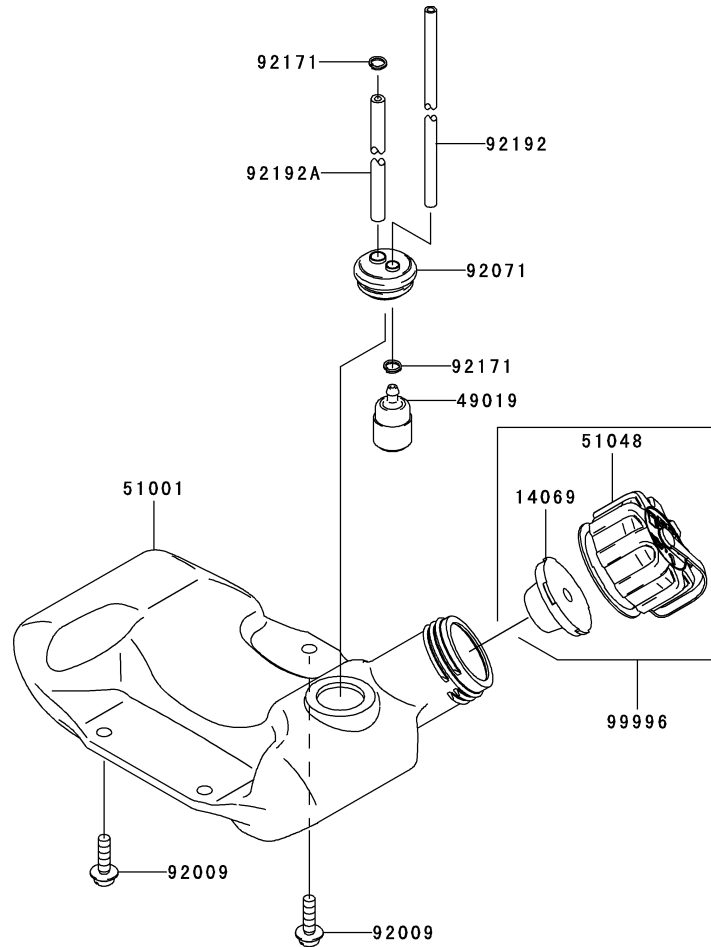

Ref. No.	Part No.	Description	Quantity
14069	14069-2088	BREATHER	1
49019	49019-2114	FILTER-FUEL	1
51001	51001-2323	TANK-COMP-FUEL	1
51048	51048-2083	CAP-ASSY-TANK	1
92009	92009-2383	SCREW,5X20	3
92071	92071-2142	GROMMET,FUEL TANK	1
92171	92171-2073	CLAMP	2
92192	92192-2130	TUBE,3X5X174	1
92192A	92192-2152	TUBE,3X6X80	1
99996	99996-6089	CAP-TANK & BREATHER,ASSY	1

This catalog covers:

TJ027E- □ **C51**

This fig. covers:

08 STARTER

E0210-A421A

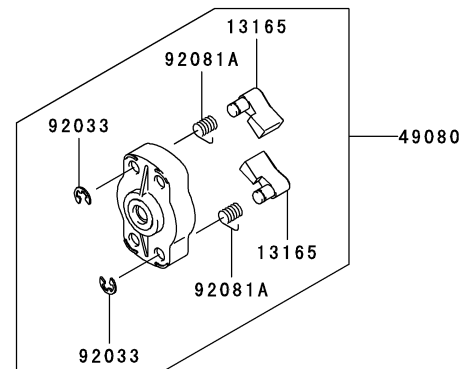
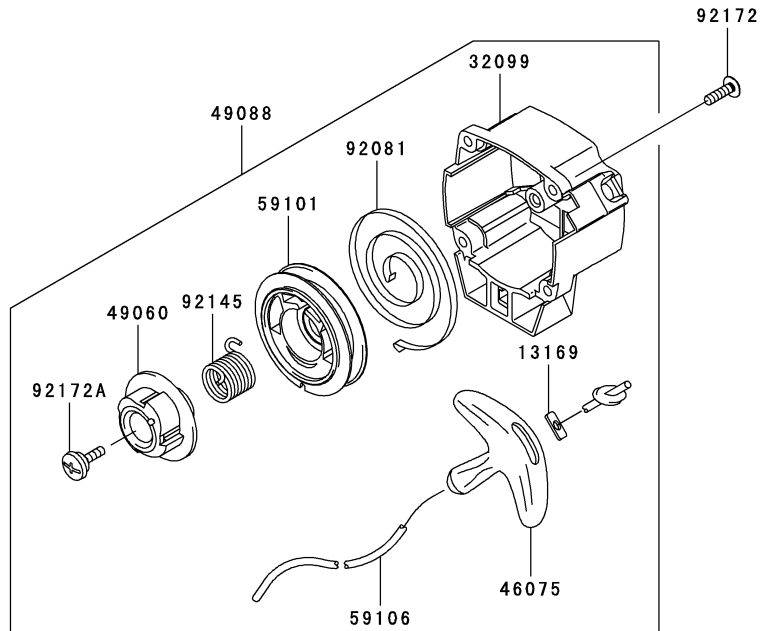

Ref. No.	Part No.	Description	Quantity
13165	13165-2100	PAWL	2
13169	13169-2386	PLATE,RECOIL STARTER	1
32099	32099-2417	CASE,STARTER-RECOIL	1
46075	46075-2159	GRIP,STARTER-RECOIL	1
49060	49060-2066	CAM,STARTER-RECOIL	1
49080	49080-2195	PULLEY-STARTING	1
49088	49088-2570	STARTER-RECOIL	1
59101	59101-2126	REEL,STARTER-RECOIL	1
59106	59106-2168	ROPE,3X700	1
92033	92033-2010	RING-SNAP	2
92081	92081-2238	SPRING,RECOIL	1
92081A	92081-2253	SPRING	2
92145	92145-2172	SPRING,RECOIL	1
92172	92172-2061	SCREW,4X14	4
92172A	92172-2065	SCREW	1

This catalog covers:

TJ027E- □ **C51**

This fig. covers:

09 P.T.O-EQUIPMENT

E0220-A039A

Ref. No.	Part No.	Description	Quantity
13081	13081-2232	CLUTCH-ASSY	1
49049	49049-2101	SHOE-CLUTCH	2
92043	92043-2243	PIN	2
92145	92145-2129	SPRING	1
92200	92200-2145	WASHER,6X16X1	2
92200A	92200-2146	WASHER	2

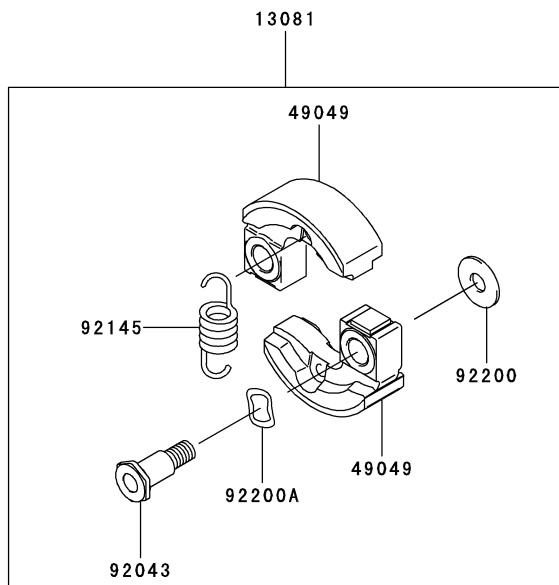

This catalog covers:

TJ027E- □ C51

10

This fig. covers:

LABEL

F0290-B365A

Ref. No.	Part No.	Description	Quantity
56039	56039-2957	LABEL-PRODUCT	1
56070	56070-2020	LABEL-WARNING	1
56080	56080-2414	LABEL-BRAND	1

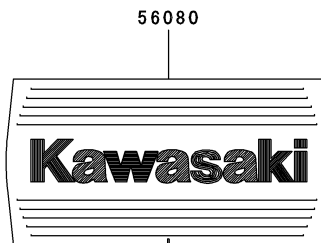
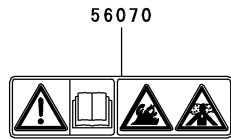
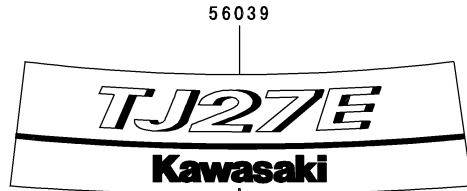

This catalog covers:

TJ027E- □ C51

This fig. covers:

PART NAME INDEX

AIR-FILTER/MUFFLER.....	06
CARBURETOR.....	05
COOLING-EQUIPMENT.....	03
CYLINDER/CRANKCASE	01
ELECTRIC-EQUIPMENT.....	04
FUEL-TANK/FUEL-VALVE.....	07
LABEL.....	10
P.T.O-EQUIPMENT.....	09
PISTON/CRANKSHAFT	02
STARTER.....	08

